

Model 600 | elevator smoke curtain

 ICC Evaluation Service Report ESR-1136



DIMENSIONS

- housing lengths: 55", 64", 73"
- custom housing lengths available
- housing height: 9"
- housing depth: 11" (plus return)
- return depths: 1/2", 3/4", and 1"

STANDARDS

- UL 1784 "Air Leakage Tests of Door Assemblies" listed by Intertek
- UL 864 "Control Units for Fire Protective Signaling Systems" listed by Intertek

CODE REFERENCES

- 2003 IBC Section 707.14.1
- 2006 IBC Section 707.14.1
- 2009 IBC Section 708.14.1
- 2012 IBC Section 713.14.1
- 2015 IBC Section 3006.1
- NFPA 105 "Installation of Smoke Control Door Assemblies"

System Description. The Smoke Guard system Model 600 (M600) creates a code compliant smoke and draft control assembly when paired with common fire-rated elevator doors. The Smoke Guard screen consists of a reinforced, transparent, polyimide film. The film edge is connected to flexible magnetic strips which adhere to ferrous metal rails as the system deploys creating a tight seal. The M600 uses standard building power.

Codes and Standards. The M600 works in conjunction with the already fire-rated elevator doors to exceed the NFPA and IBC requirements for a smoke and draft control assembly. This enables the elevator to open directly onto the corridor, eliminating the need for additional doors at the elevator constructed lobby space.

System Operation. The Smoke Guard system will deploy when the smoke detector in front of the elevator opening goes into alarm (or on loss of power to the unit). The system is not designed to deploy on general alarm. If an elevator occupant were to encounter a deployed M600, a screen rewind switch located on both sides of the screen allows for egress. If AC power is lost, the Smoke Guard system M600 operates on a fail safe basis, triggering screen deployment. A deployment delay is built into the system to avoid nuisance deploys on brief power outage. As power is restored, the screen will automatically rewind into the housing.

Unit Dimensions. The M600 is available in standard screen sizes which will cover openings up to an 8' clear opening. Curtains greater than 78 1/4" (clear opening width + 2 1/4") are certified by a report. Performance information on these larger curtains is available upon request.

Installation. All Smoke Guard units are installed by factory recognized personnel. There is minimal preparation work. Installation requires a clear, plumb, unobstructed wall surface above the hoistway door, 120v AC power and a smoke detector.



Model 600 | elevator smoke curtain

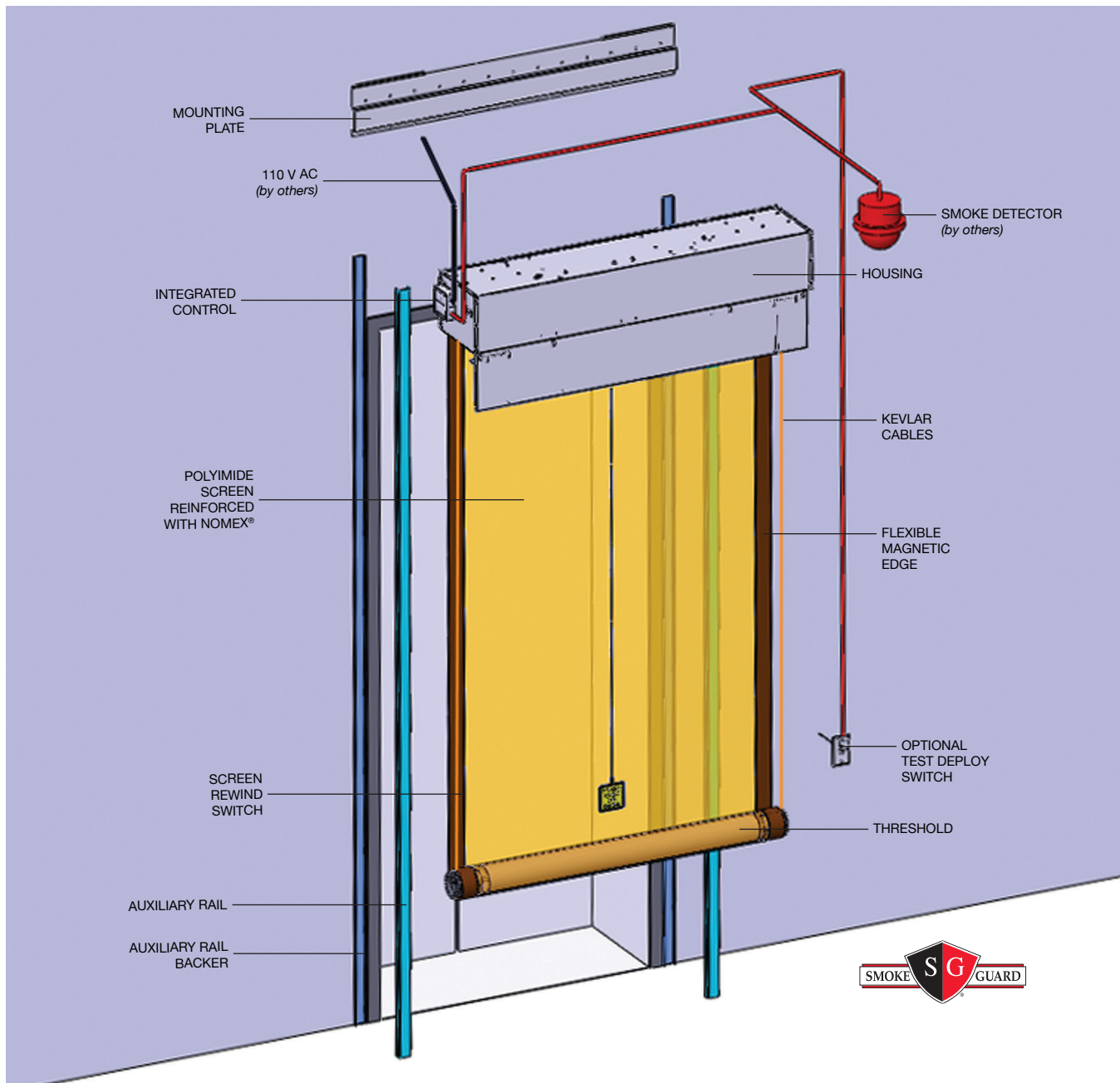

US PATENTED

Releasing Device. Contained within the unit housing the M600 is tested in accordance with the UL 864 standard by Intertek Laboratories.

System Monitoring. The unit control monitors several system functions including presence of AC power, battery backup condition, system deploy status, and the continuity of all system circuits. The M600 is a dedicated smoke control device (NFPA 92 A & B) compatible with UUKL controls.

Battery Backup. The M600 unit operates on standard 110 V AC building power. In addition, M600 has a battery backup system.

External Indicators. External indicators display if a fault is detected. System warnings include partial curtain deployment and blinking LED status indicator lights on the housing frame to aid building maintenance personnel in easily diagnosing system faults.

Object Sensing. If the curtain senses an object in its path the system will redeploy after the obstruction is removed.